



YCCE, Nagpur



MGI

7 segment display with 8051

Dr. P. T. Karule

Professor

Department of Electronics Engineering

Yeshwantrao Chavan College of Engineering, Nagpur (M. S.)

Email: ptkarule@ycce.edu

Website: www.ycce.edu

Interfacing with 8051

- LED, Key
- 7 segment display
- Keyboard
- DAC
- ADC
- Stepper Motor
- LCD
- I2C Bus

Minimum 8051 Circuit

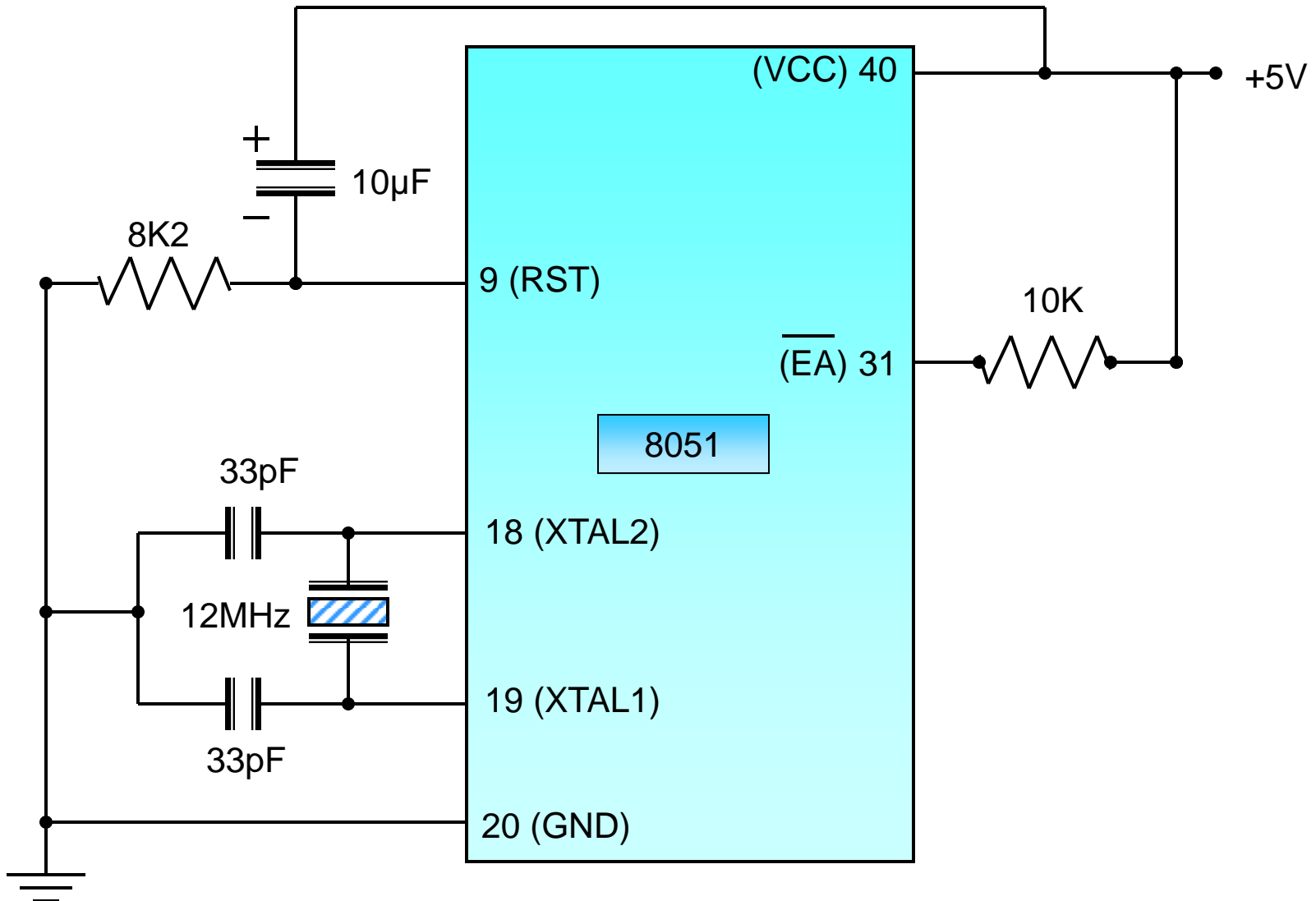



LED & Switch

Example #1

🔔 LED interface

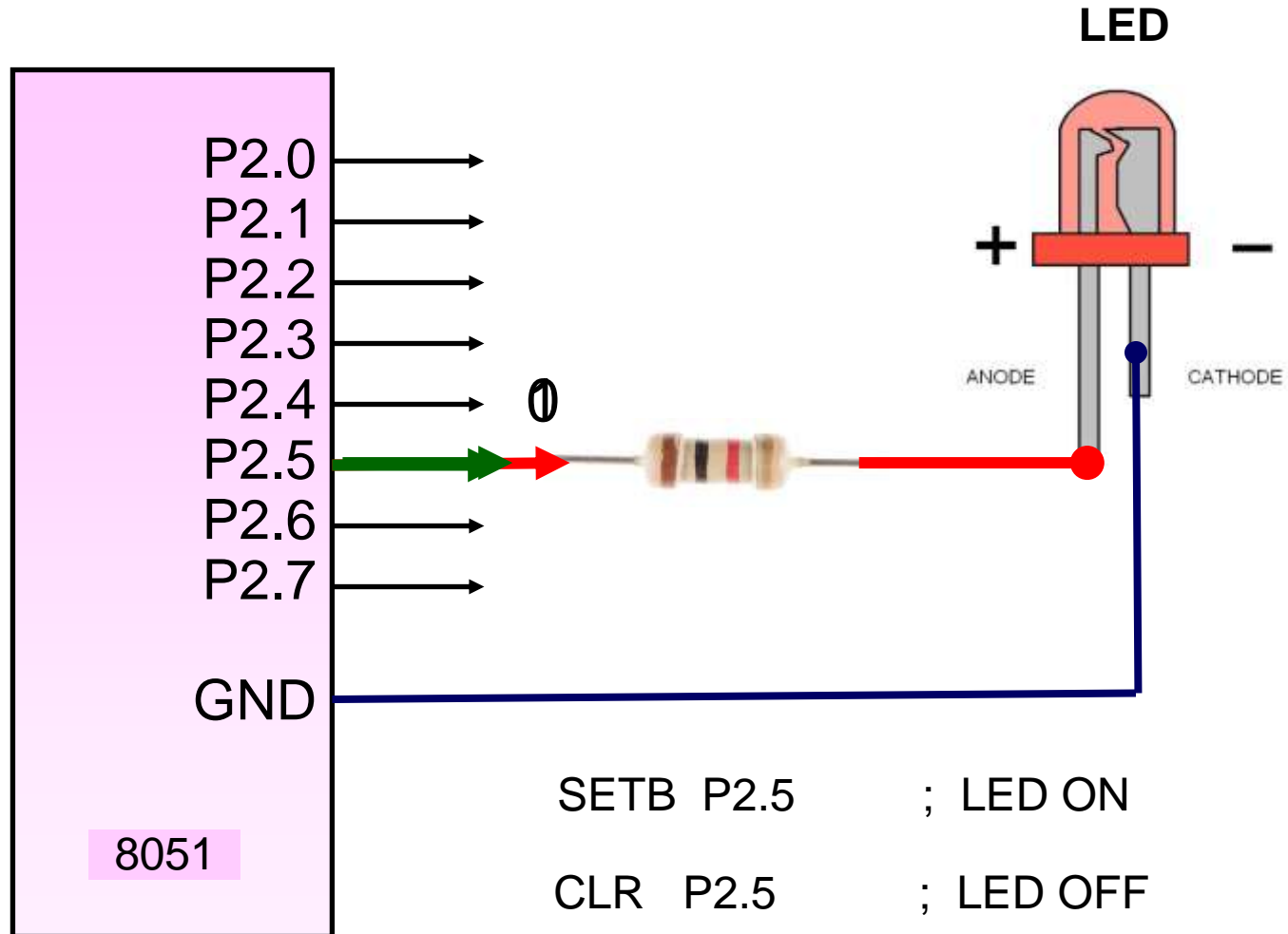

Q. Write program to blink LED

Main Program

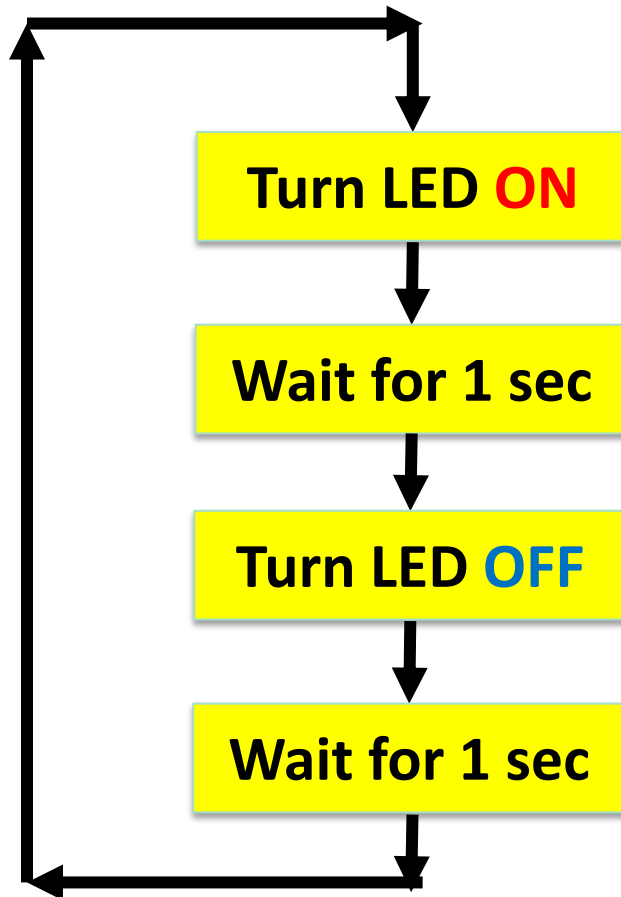

Sub Program

Delay Program
 $N = N - 1$
Till $N = 0$

Q. Write program to blink LED

■ Program:

```
    $MOD51
    ORG 0000H
    SJMP START
    ORG 0040H
START: SETB P2.5           ; LED ON
       ACALL delay_1sec   ; 1 sec delay
       CLR P2.5          ; LED OFF
       ACALL delay_1sec   ; 1 sec delay
       SJMP START

; Subroutine for delay
delay_1sec: MOV R2,#04H
           L4: MOV R3,#0FFH
           L3: MOV R4,#0FFH
           L2: DJNZ R4,L2
              DJNZ R3,L3
              DJNZ R2,L4
           RET
END
```

Example #2

🔔 Switch interface

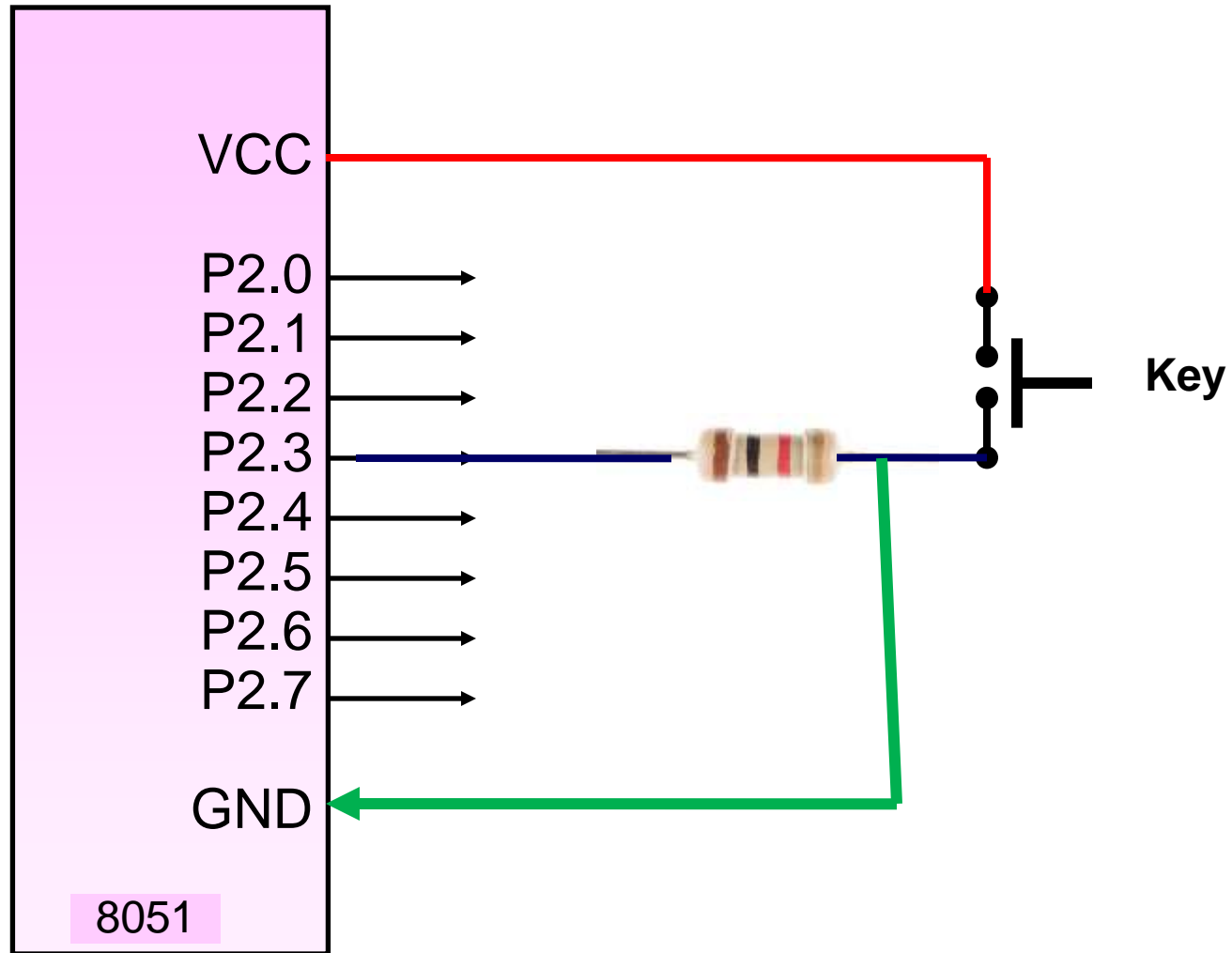

Q. Write Program to check Key Press?

 Push Button interface

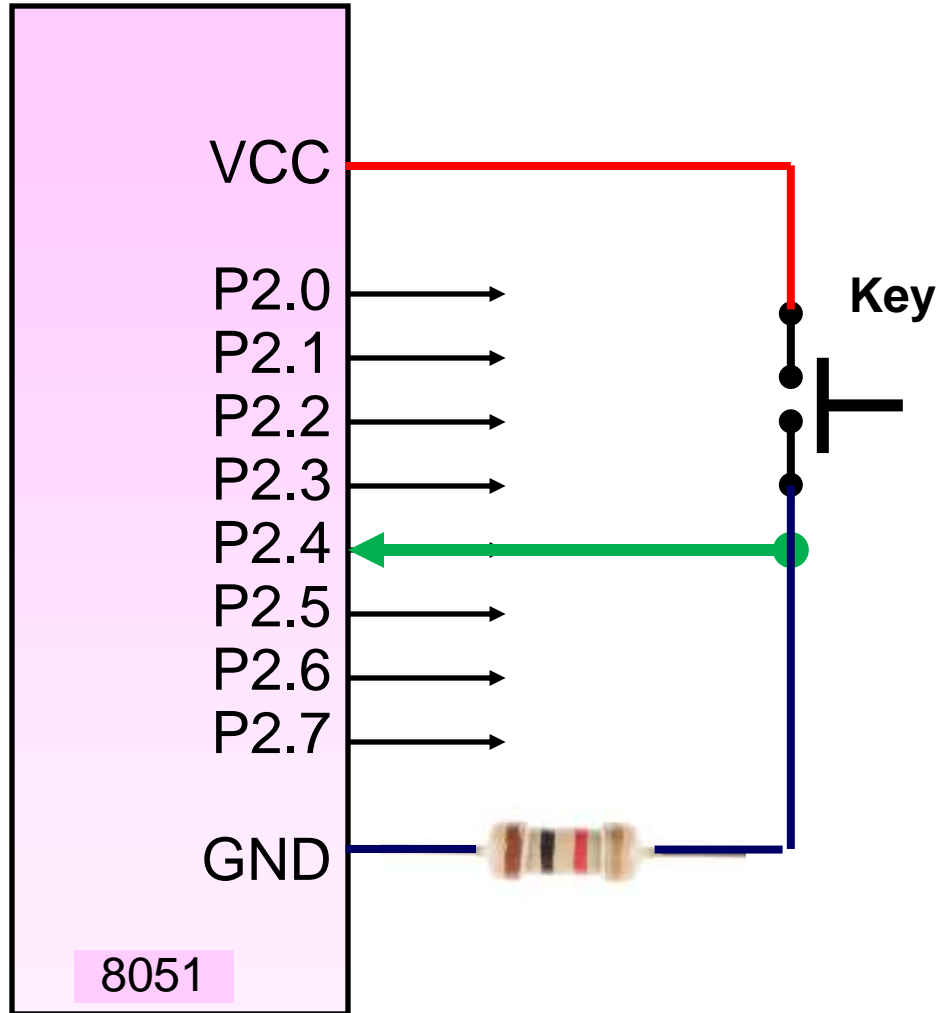

```
JNB P2.4, L1
```

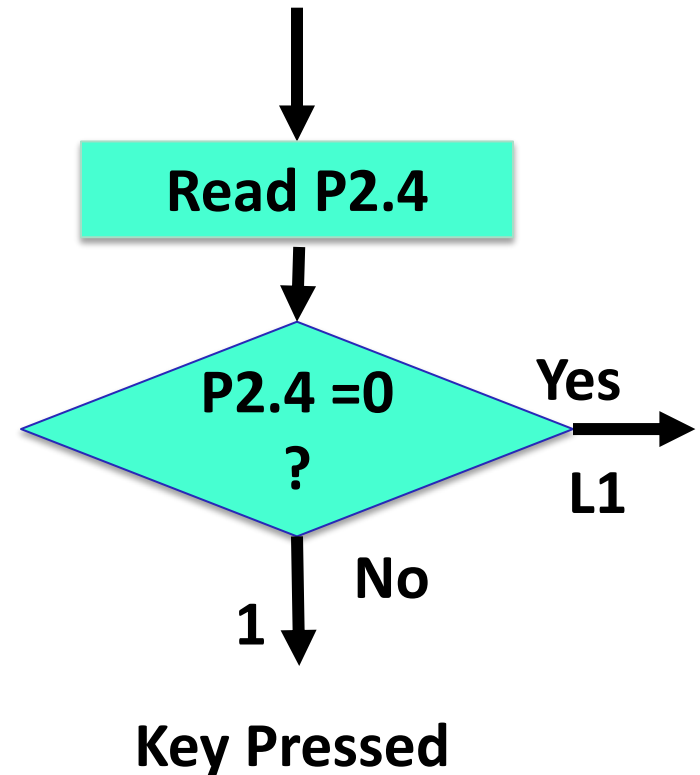



7 Segment Display

Example #1

🔔 Common Anode Seven Segment Display is connected with P2 of 8051 and write program to display 0 to F at an interval of 1 sec.

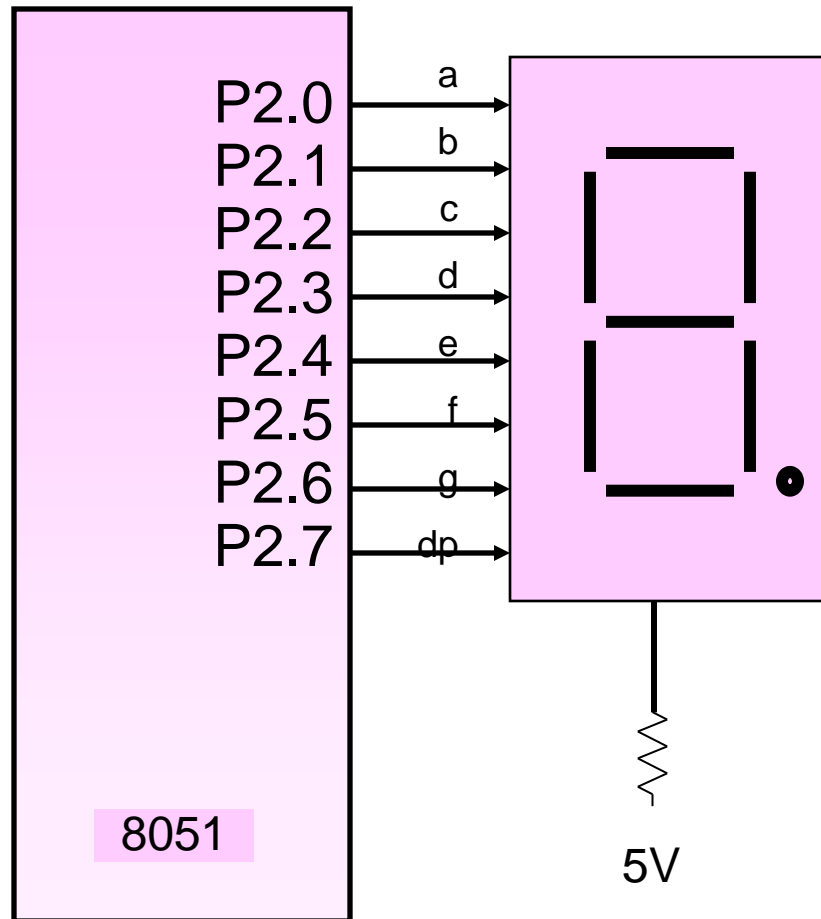

Digit	7 segment Code dp g f e d c b a	Hex code
0	1 1 0 0 0 0 0 0	C0H
1	1 1 1 1 1 0 0 1	F9H
2	1 0 1 0 0 1 0 0	A4H
3	1 0 1 1 0 0 0 0	B0H
4	1 0 0 1 1 0 0 1	99H
5	1 0 0 1 0 0 1 0	92H
6	1 0 0 0 0 0 1 0	82H
7	1 1 1 1 1 0 0 0	F8H
8	1 0 0 0 0 0 0 0	80H
9	1 0 0 1 0 0 0 0	90H
A	1 0 0 0 1 0 0 0	88H
b	1 0 0 0 0 0 1 1	83H
C	1 1 0 0 0 1 1 0	C6H
d	1 0 1 0 0 0 0 1	A1H
E	1 0 0 0 0 1 1 0	86H
F	1 0 0 0 1 1 1 0	8EH

Example #1 (cont..)

■ Flowchart

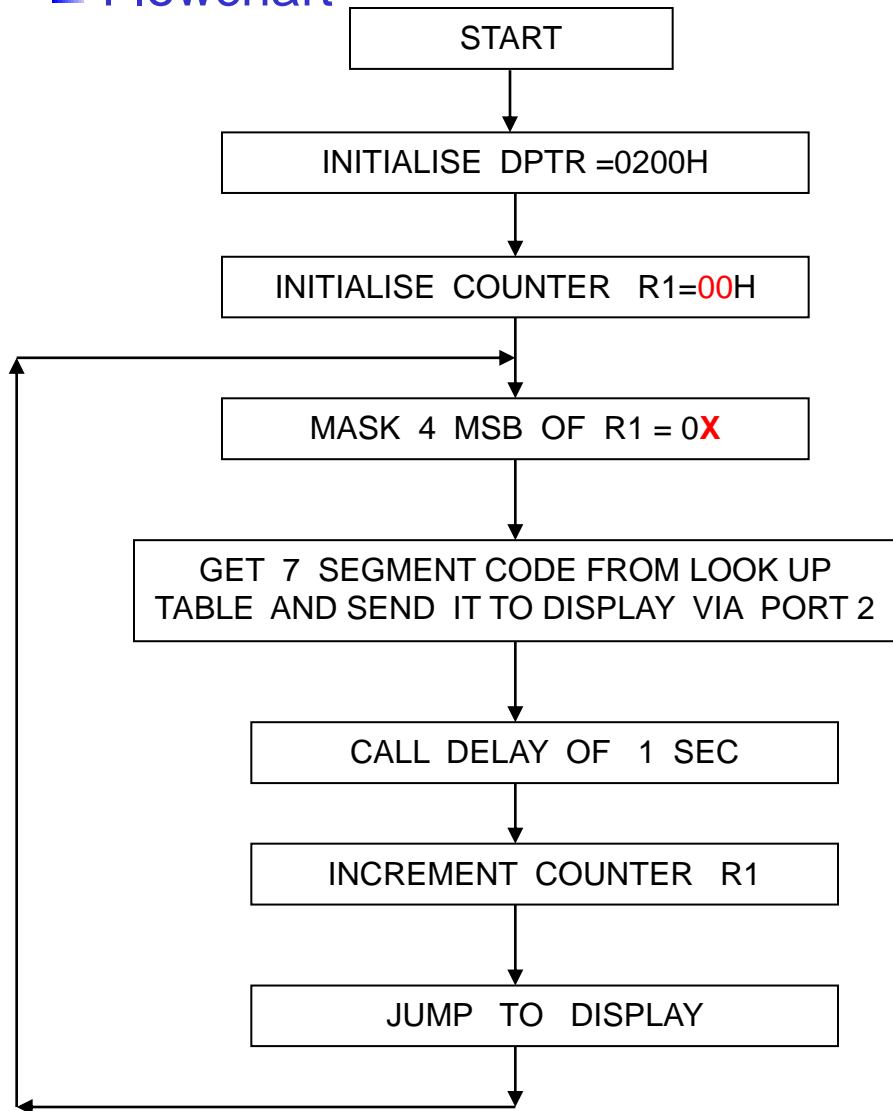

■ Program

```
$MOD51
MOV DPTR,#0200H
MOV R1, #00H
L1: MOV A, R1
ANL A, 0FH
MOVC A, @A+DPTR
MOV P2, A
ACALL delay
INC R1
SJMP L1

ORG 0200H
DB 0C0H, 0F9H, 0A4H, 0B0H
DB 99H, 92H, 82H, 0F8H, 80H
DB 90H, 88H, 83H, 0C6H
DB 0A1H, 86H, 8EH
END
```

Example #2

🔔 Common Anode Seven Segment Display is connected with P0 (4 LSB) through IC 7447 and write program to display 0 to 9 at an interval of 1 sec.

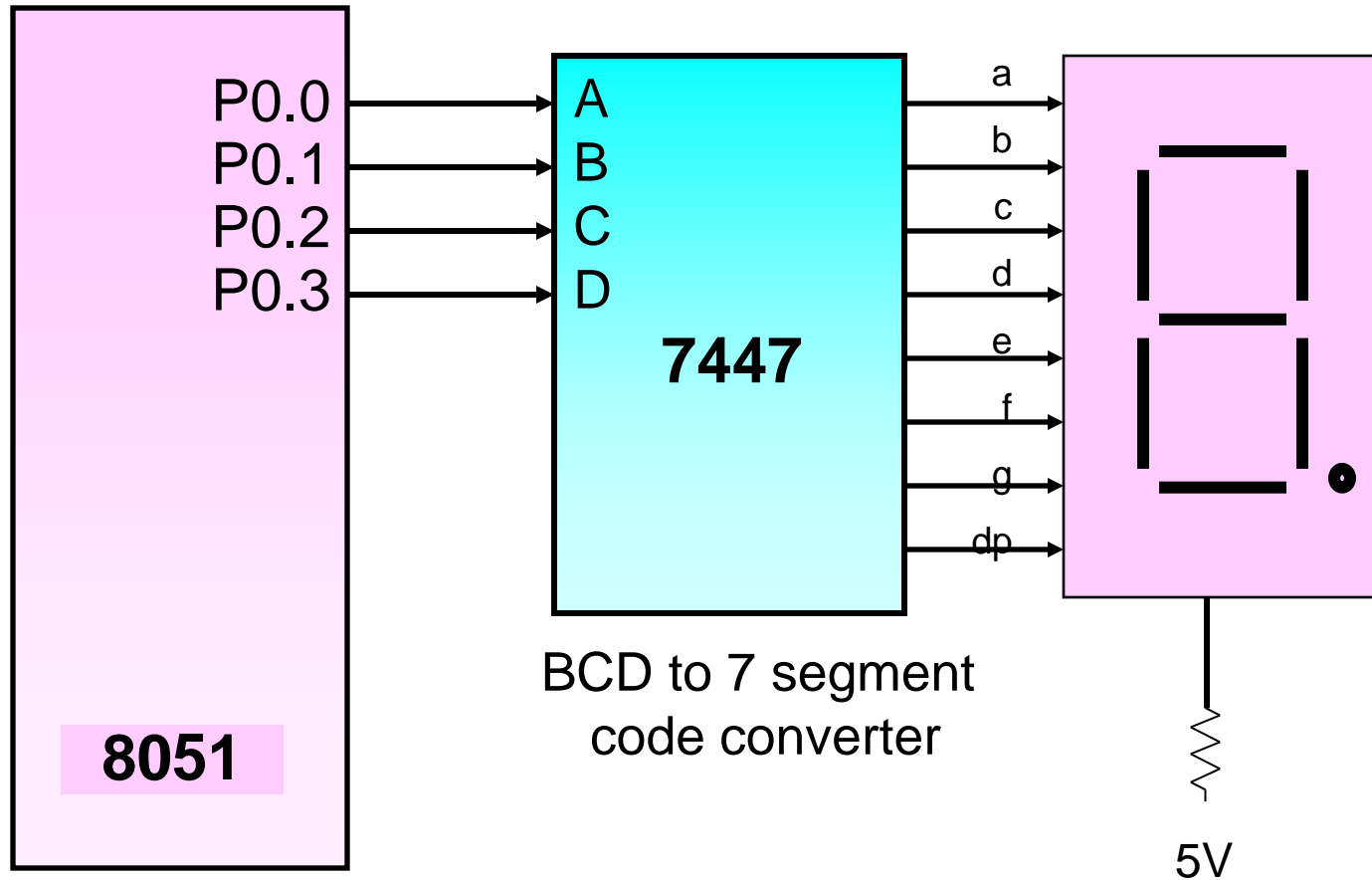

Example #1 (cont..)

■ Flowchart

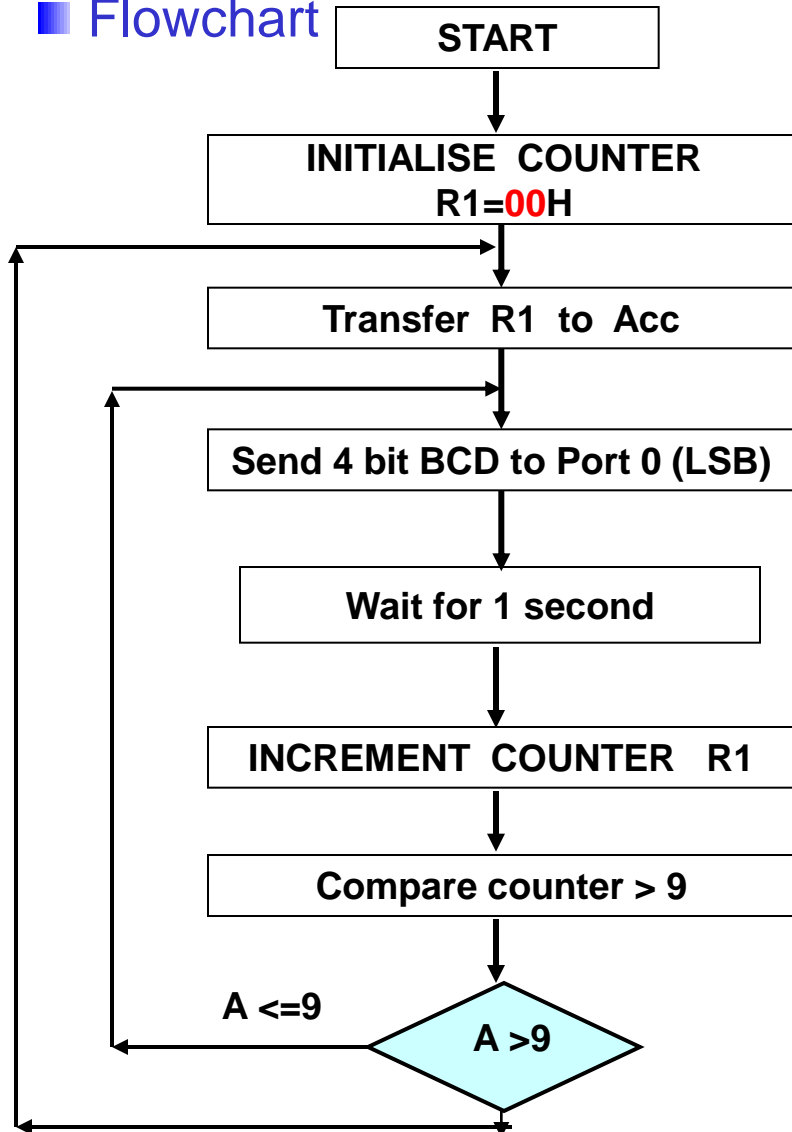

■ Program

```
$MOD51
ORG 0000H
MOV SP,#40H
L5: MOV R1,#00H
L1: MOV A,R1
MOV P0,A ; send it to display
ACALL delay_1sec
INC R1
CJNE R1,#0AH,L1 ;(A) > 9
SJMP L5
; Subroutine for delay
delay_2sec: MOV R2,#08H
L4: MOV R3,#0FFH
L3: MOV R4,#0FFH
L2: DJNZ R4,L2
DJNZ R3,L3
DJNZ R2,L4
RET
END
```

Interfacing 7 segment display

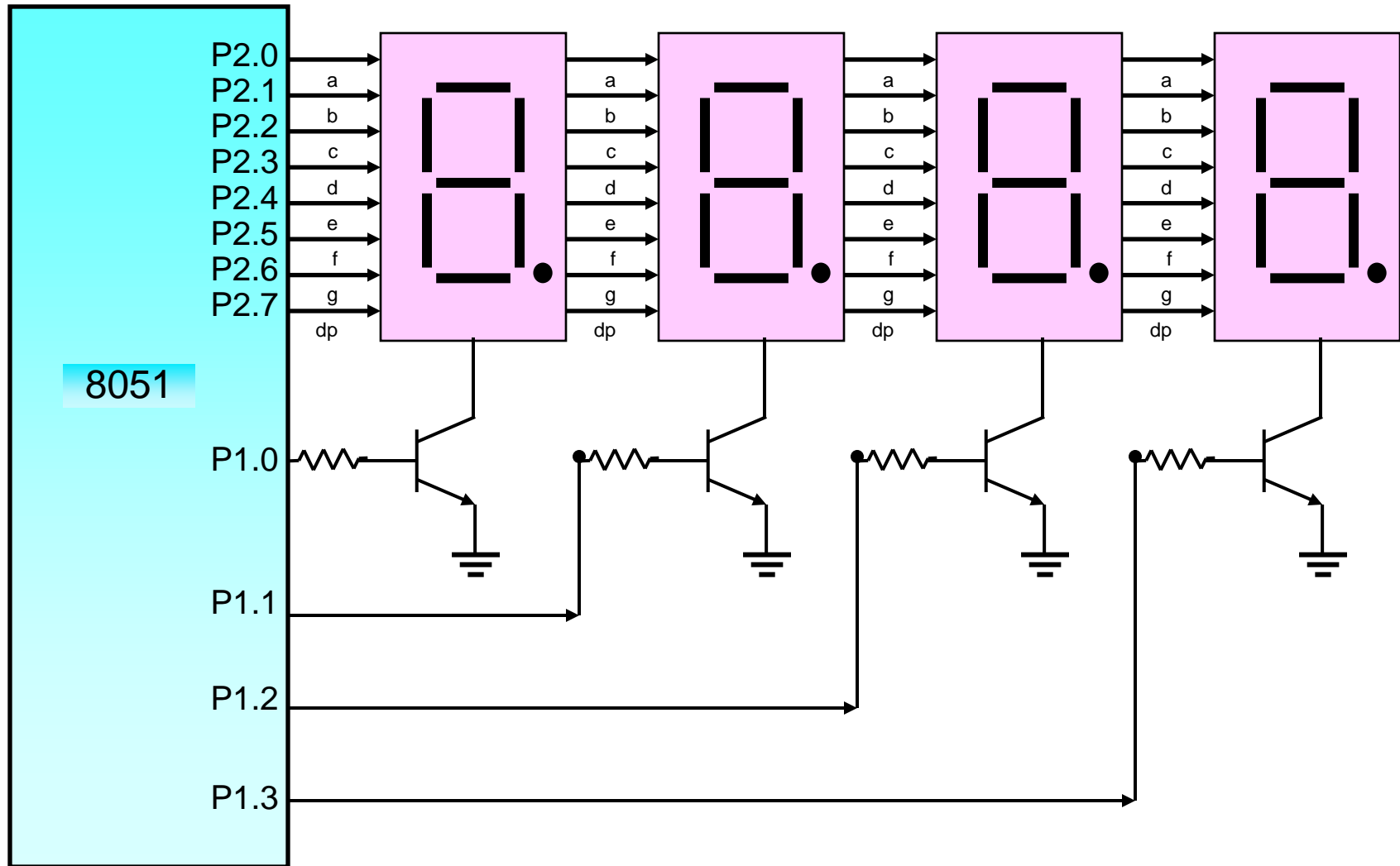

Interfacing 7 segment display

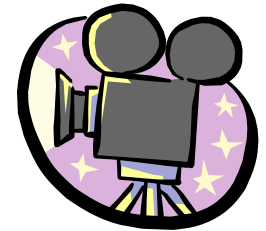
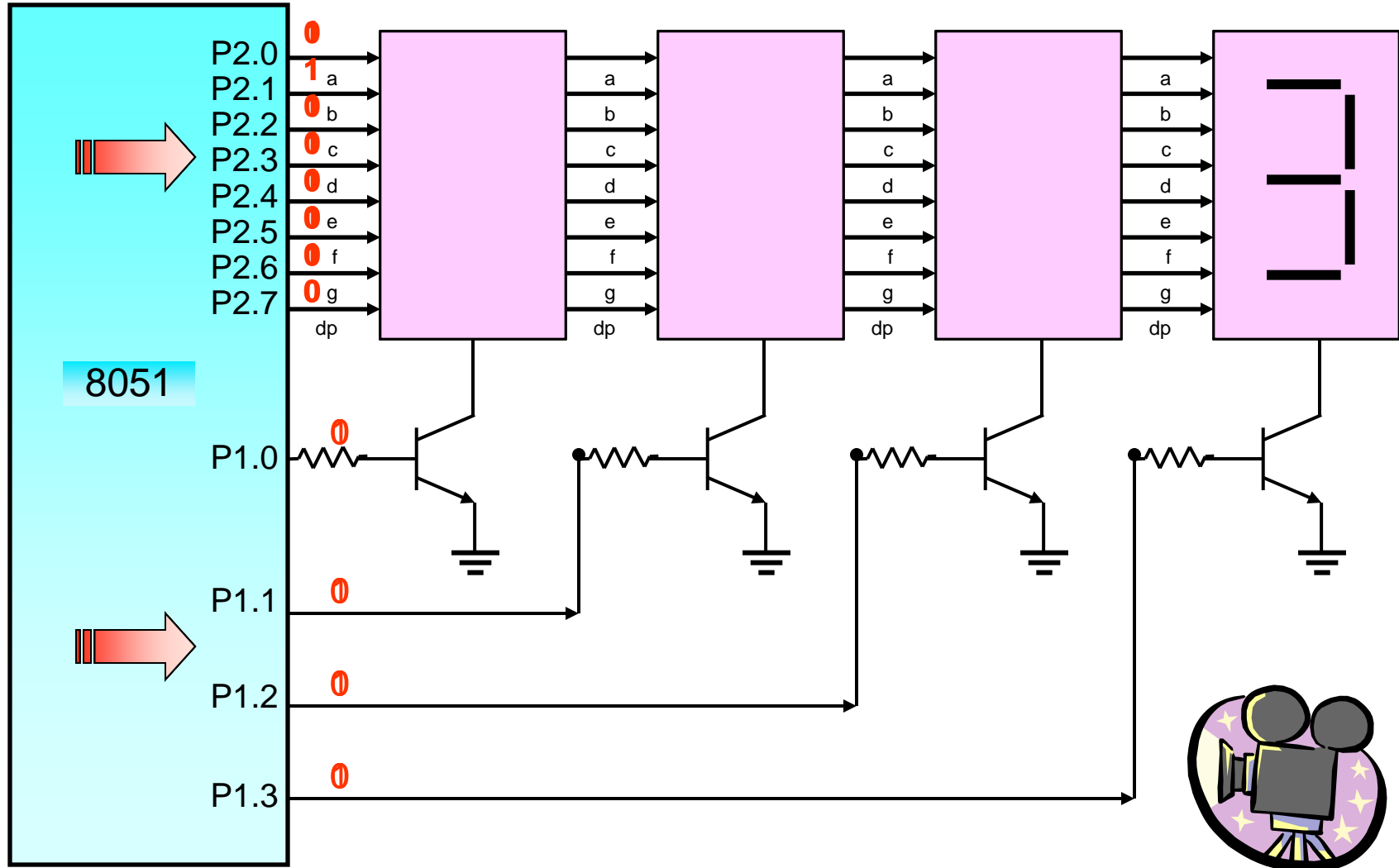

Interfacing two digit 7 segment display

